



US 20090056191A1

(19) **United States**
(12) **Patent Application Publication**
Battaglia

(10) **Pub. No.: US 2009/0056191 A1**
(43) **Pub. Date: Mar. 5, 2009**

(54) **FIREARM ACCESSORY MOUNTING SYSTEM**

(60) Provisional application No. 60/564,895, filed on Apr. 23, 2004.

(75) Inventor: **Vincent P. Battaglia**, Easton, CT (US)

Publication Classification

(51) **Int. Cl.**
F41C 23/16 (2006.01)
(52) **U.S. Cl.** **42/71.01**

Correspondence Address:

PERMAN & GREEN
425 POST ROAD
FAIRFIELD, CT 06824 (US)

(57) **ABSTRACT**

A firearm having a barrel and an accessory mounting system. The accessory mounting system has a hand guard surrounding a portion of the barrel and fastening features coupled to the hand guard. Peripheral device mounting rails are coupled to the fastening features and located in a generally "Y" shape pattern. The generally "Y" shape pattern has a first peripheral device mounting rail located on a lower portion of the hand guard and second and third peripheral device mounting rails located on opposing sides of an upper portion of the hand guard. The peripheral device mounting rails are placed where peripheral devices mounted on the peripheral device mounting rails do not interfere with a line of sight of the firearm.

(73) Assignee: **Colt Defense LLC**, Hartford, CT (US)

(21) Appl. No.: **12/174,370**

(22) Filed: **Jul. 16, 2008**

Related U.S. Application Data

(62) Division of application No. 11/113,525, filed on Apr. 25, 2005, now abandoned.

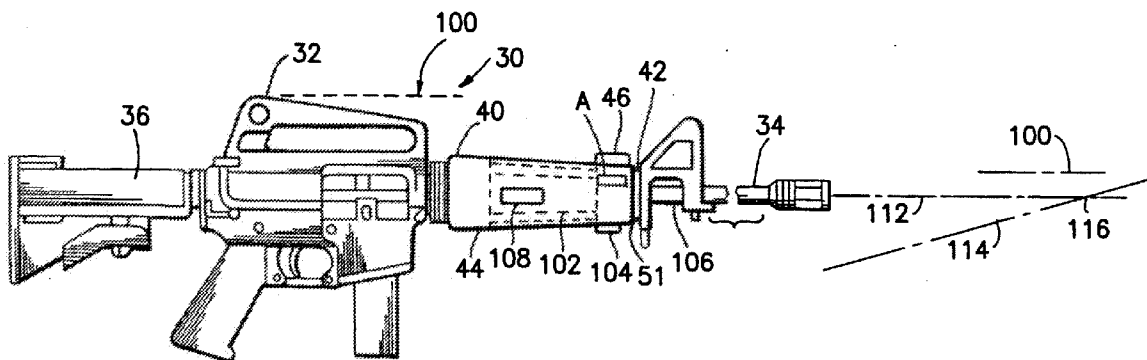

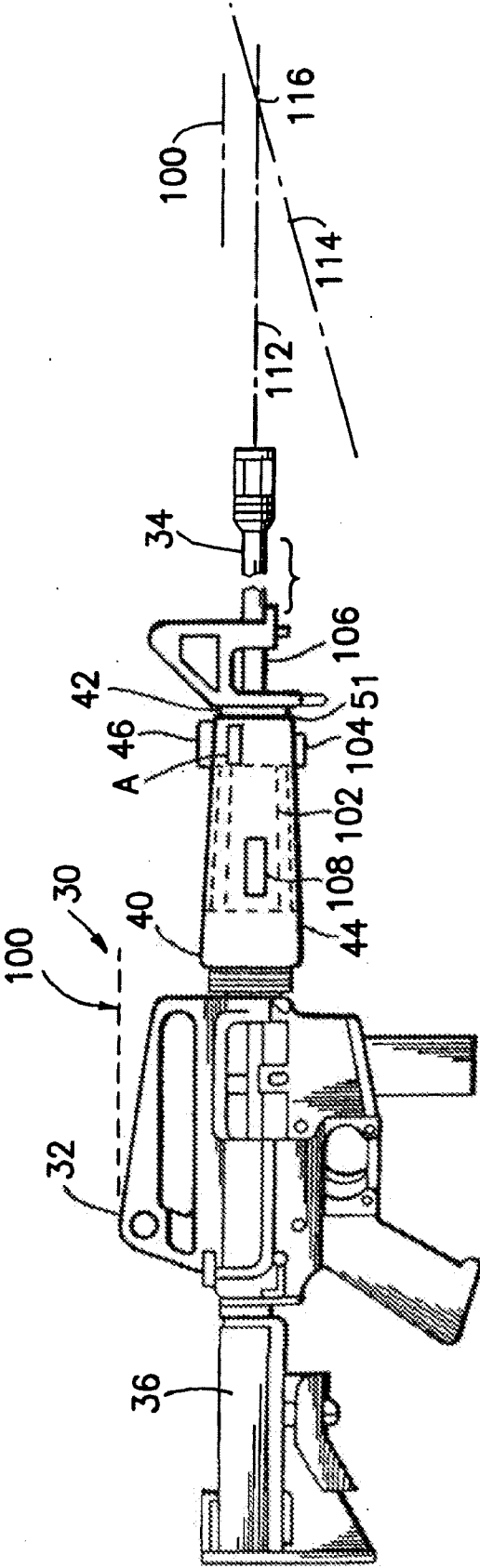
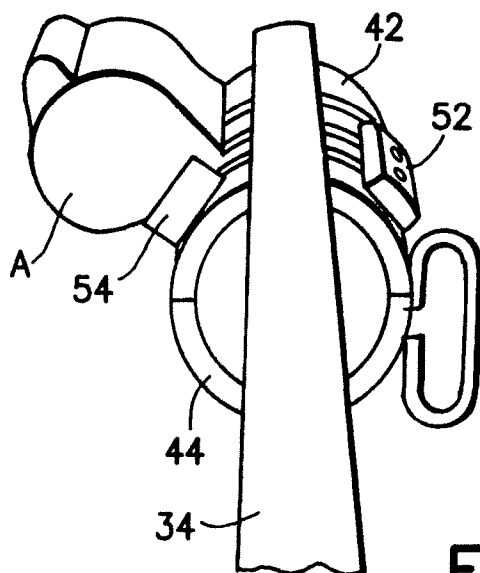
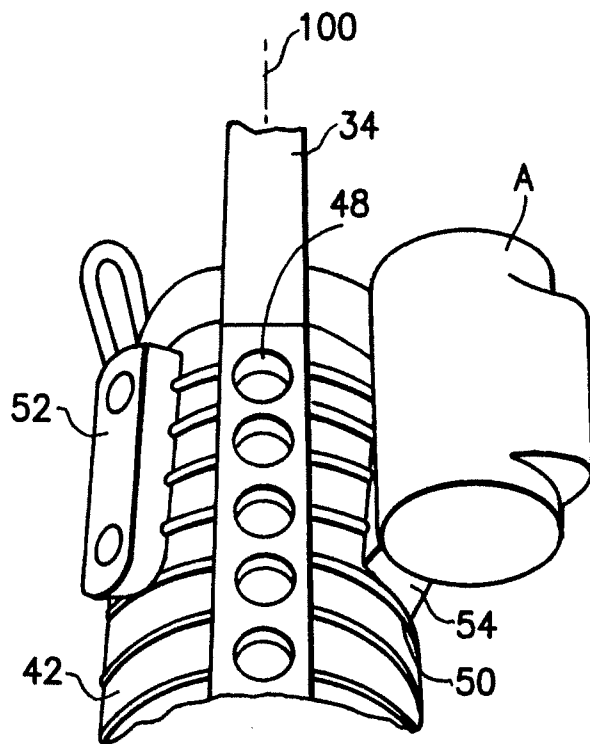
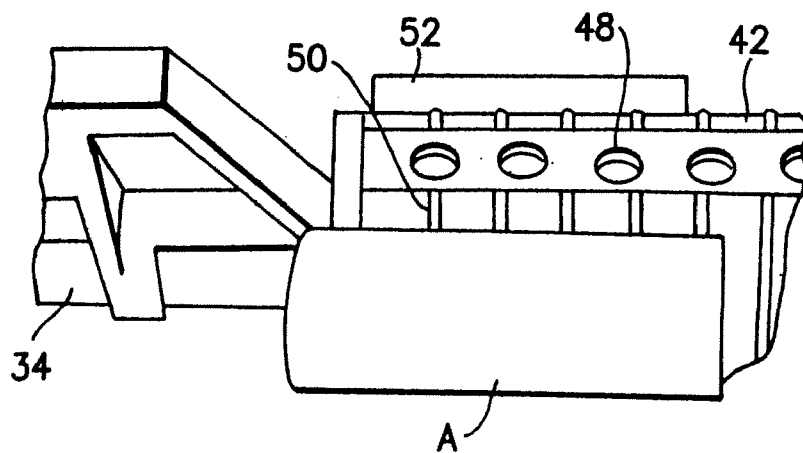
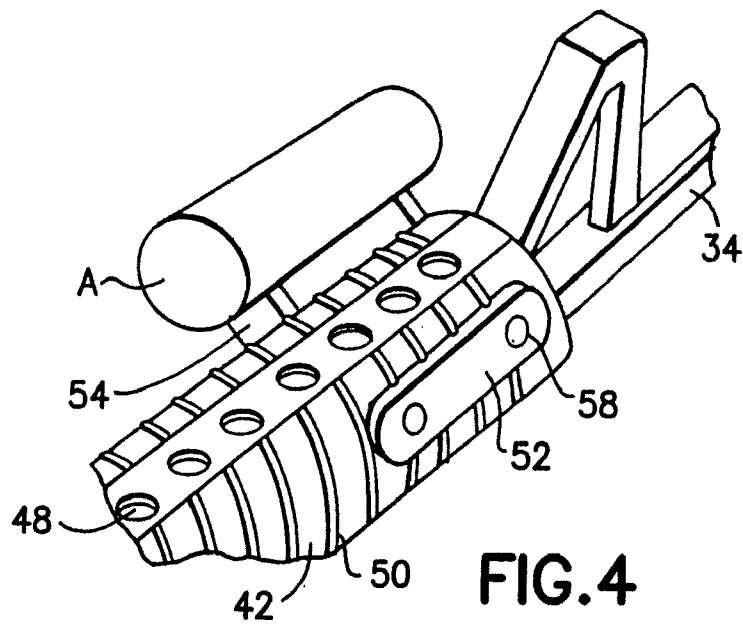

FIG.1





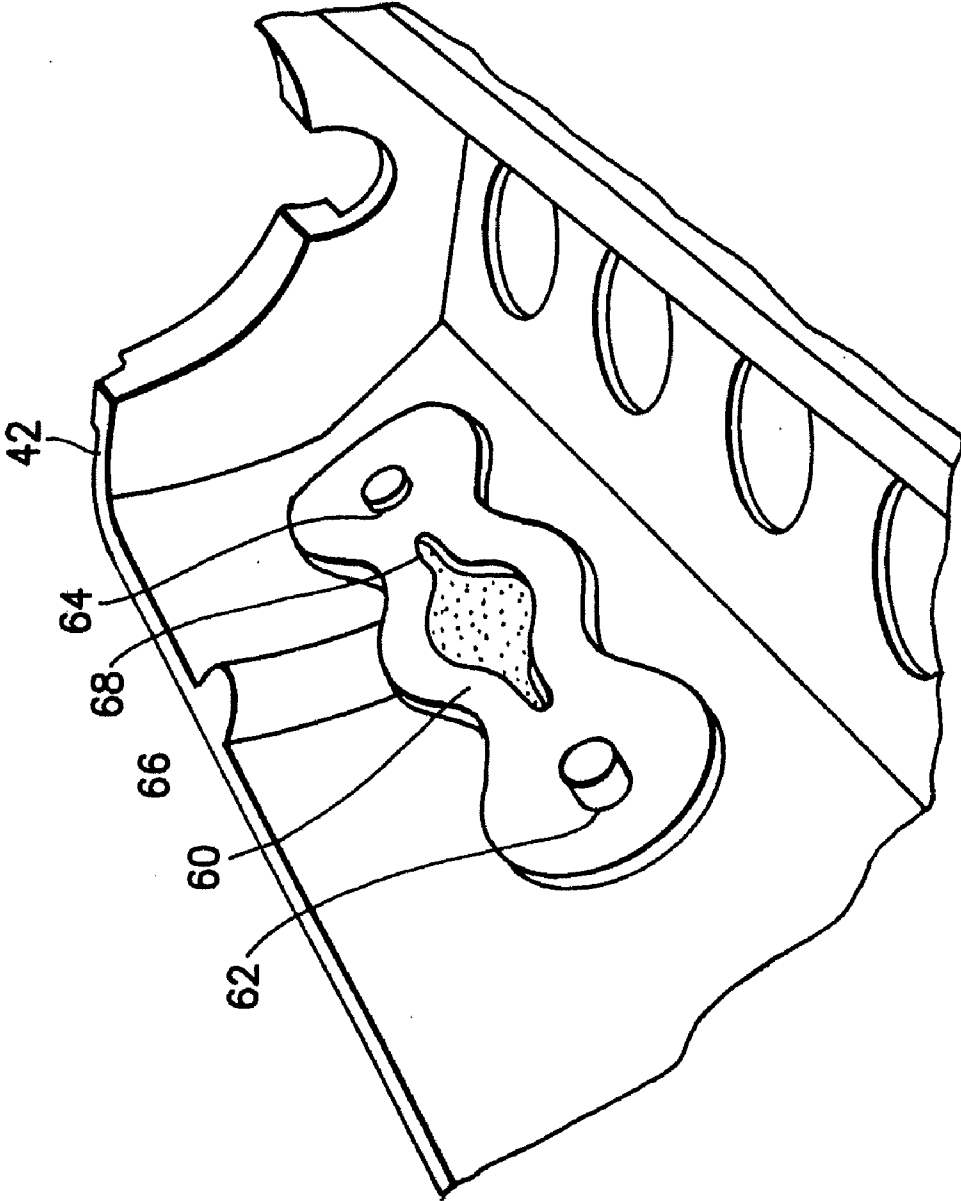

FIG.6

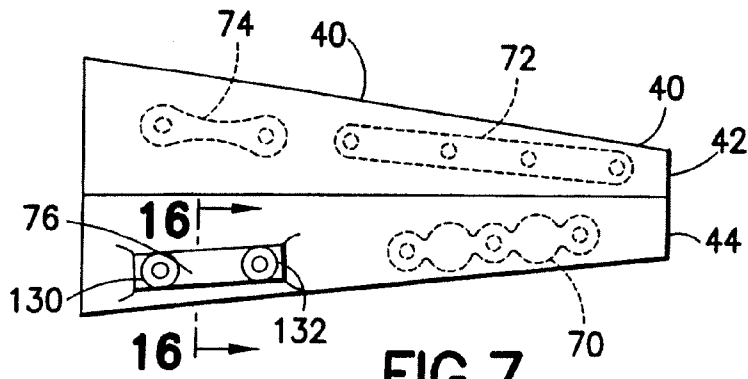

FIG. 7

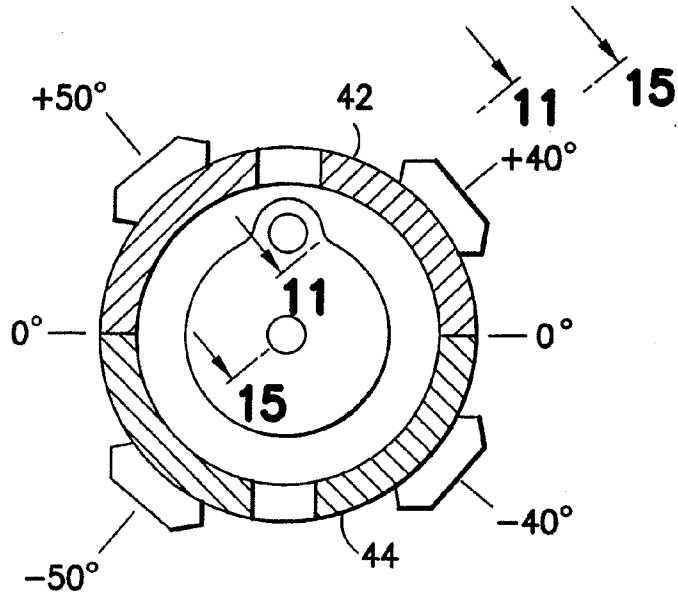

FIG. 8

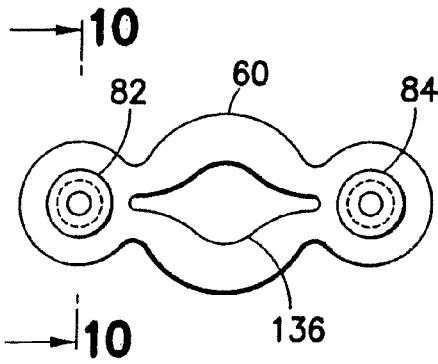

FIG. 9

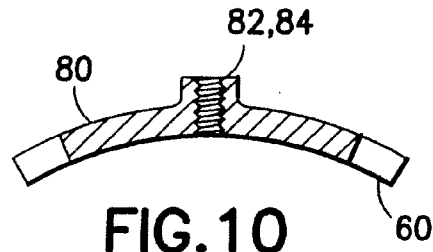

FIG. 10

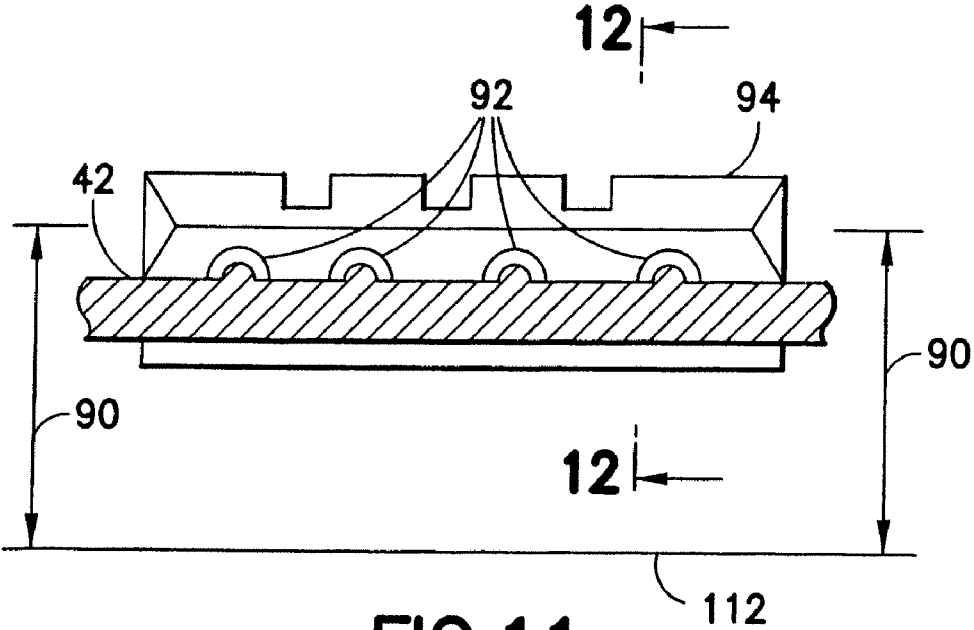

FIG. 11

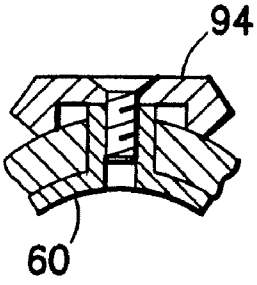

FIG. 12

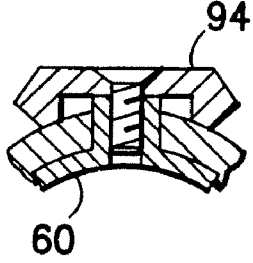

FIG. 13

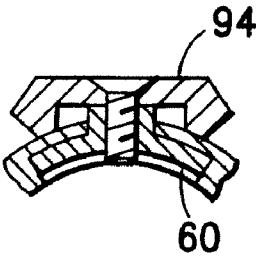

FIG. 14

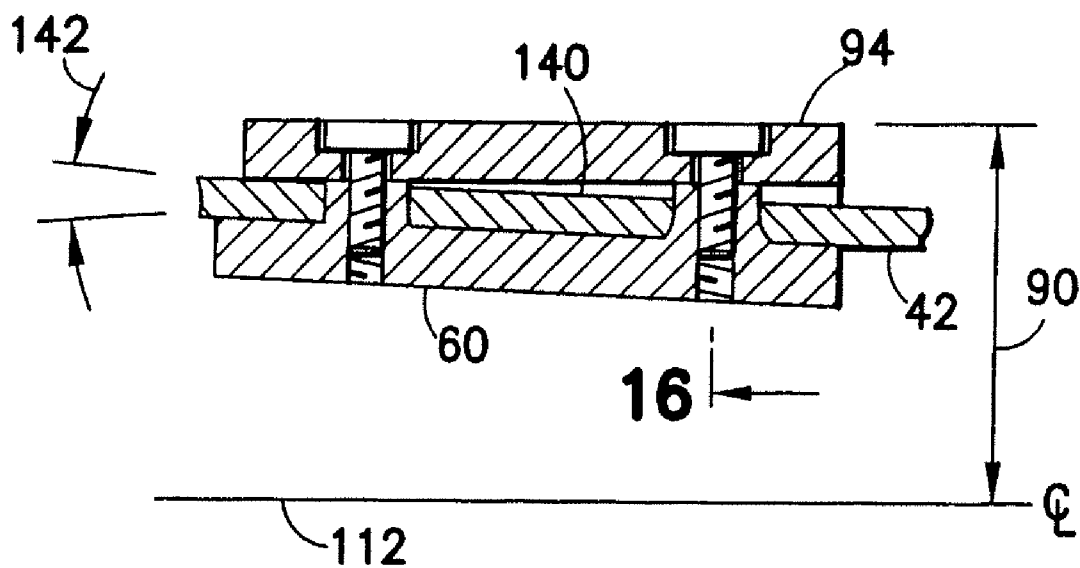

FIG. 15

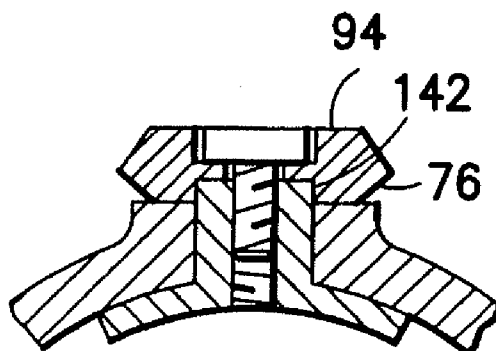

FIG. 16

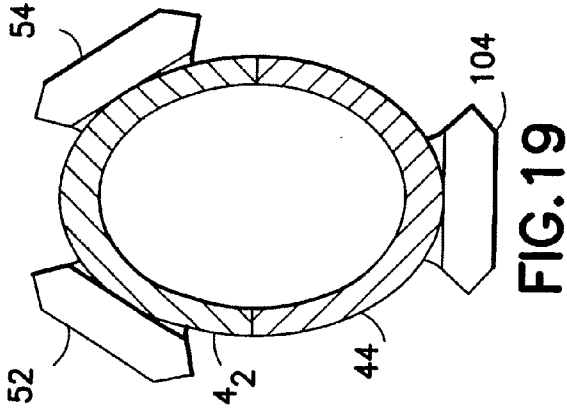

FIG. 17

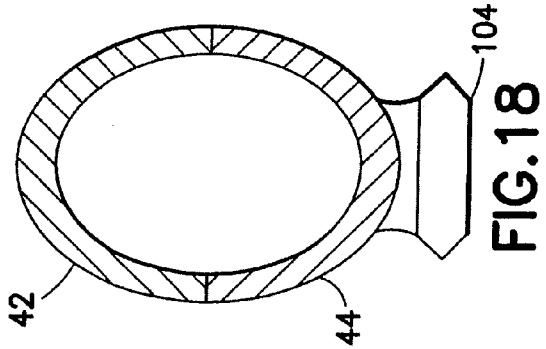

FIG. 18

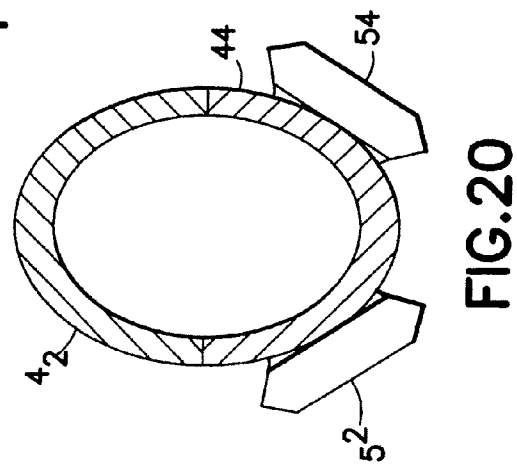

FIG. 19

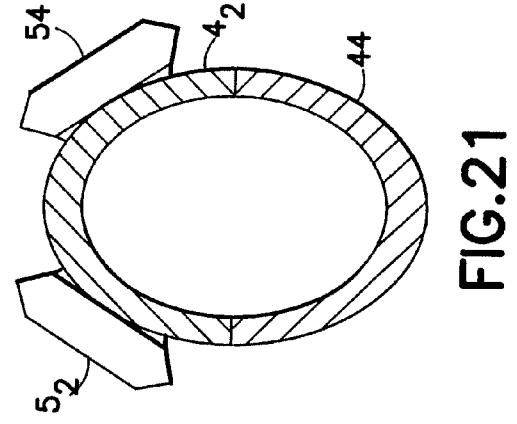

FIG. 20

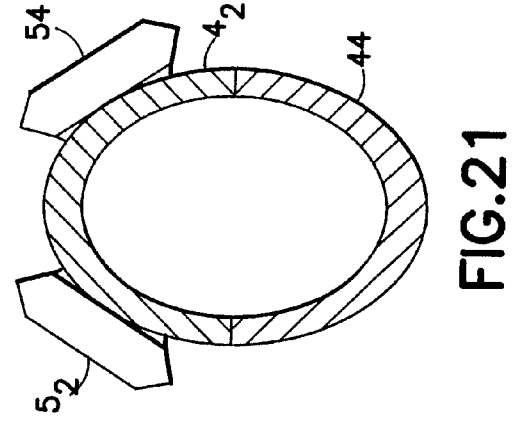

FIG. 21

FIREARM ACCESSORY MOUNTING SYSTEM

[0001] This application is a division of U.S. application Ser. No. 11/113,525, filed Apr. 25, 2005 and claims the benefit of U.S. Provisional Application No. 60/564,895, filed Apr. 23, 2004.

BACKGROUND

[0002] 1. Field of the Invention

[0003] The present invention relates to a firearm accessory mounting system and, more particularly, to a mounting system for mounting accessories on M4 and M16 firearms.

[0004] 2. Brief Description of Related Developments

[0005] Combat firearms typically require a hand guard assembly to allow a user to effectively grip the firearm, to facilitate barrel cooling and protect the user from high temperature surfaces. As an example, Tatro, U.S. Pat. No. 4,663,875 which is hereby incorporated by reference in its entirety, discloses a hand guard assembly for a rifle barrel with mating sections. In this example, the hand guard has a highly ergonomic elliptical cross-section, and includes outer and inner liners for improved cooling and lower temperatures of contact surfaces that are highly desirable. It is further desirable to attach various accessory devices, such as flashlight, sighting devices, grips, supports to the firearm and in particular, to the hand guard. As an example, Olson, U.S. Pat. No. 5,826,363 which is hereby incorporated by reference in its entirety, discloses a rail adapter system to support accessory devices on a hand guard. A problem arises when the user desires the flexibility of mounting the accessories on different locations of the hand guard without mounting features, such as rails, being provided in positions that are not populated by accessories. An additional problem arise when the user desires the flexibility of mounting the accessories on different locations of the hand guard without an excessively heavy or thermally inefficient hand guard assembly. Accordingly, there is a desire to provide a thermally efficient, light weight firearm hand guard assembly that provides flexible accessory mounting without interfering with the handling surfaces for the user.

SUMMARY

[0006] In accordance with one exemplary embodiment, a firearm having a barrel and an accessory mounting system is provided. The accessory mounting system has a hand guard surrounding a portion of the barrel and fastening features coupled to the hand guard. Peripheral device mounting rails are provided coupled to the fastening features and located in a generally "Y" shape pattern. The generally "Y" shape pattern has a first peripheral device mounting rail located on a lower portion of the hand guard and second and third peripheral device mounting rails located on opposing sides of an upper portion of the hand guard. The peripheral device mounting rails are placed where peripheral devices mounted on the peripheral device mounting rails do not interfere with a line of sight of the firearm.

BRIEF DESCRIPTION OF THE DRAWINGS

[0007] The foregoing aspects and other features of the exemplary embodiments are explained in the following description, taken in connection with the accompanying drawings, wherein:

[0008] FIG. 1 is a side elevation view of an automatic firearm incorporating features in accordance with an exemplary embodiment and an accessory A mounted to the firearm;

[0009] FIG. 2 is a partial top isometric view of the hand guard section of the firearm and accessory A shown in FIG. 1;

[0010] FIG. 3 is a partial front isometric view of the hand guard section of the firearm and accessory A shown in FIG. 1;

[0011] FIG. 4 is a partial side elevation view of the hand guard section of the firearm and accessory A shown in FIG. 1 as seen from one direction;

[0012] FIG. 5 is another partial side elevation view of the hand guard section of the firearm and accessory A shown in FIG. 1 as seen from another direction;

[0013] FIG. 6 is an isometric view of an interior portion of the hand guard section of the firearm shown in FIG. 1;

[0014] FIG. 7 is a side schematic elevation view of the hand guard section of the firearm shown in FIG. 1;

[0015] FIG. 8 is a schematic cross-sectional view of the hand guard section of the firearm shown in FIG. 1;

[0016] FIG. 9 is a top elevation view of an accessory mounting system insert of the firearm in FIG. 1;

[0017] FIG. 10 is a section view of the insert shown in FIG. 9;

[0018] FIG. 11 is another partial section view of the hand guard section taken along lines 11-11 in FIG. 8;

[0019] FIG. 12 is a partial section view taken along lines 12-12 in FIG. 11 showing a section of the hand guard section in accordance with one exemplary embodiment;

[0020] FIG. 13 is a partial section view similar to the section view of FIG. 12 but showing a section of the hand guard section in accordance with another embodiment;

[0021] FIG. 14 is another partial section view similar to the section view in FIG. 12 but showing a section of the hand guard section in accordance with yet another embodiment;

[0022] FIG. 15 is another partial section view of the hand guard section of the firearm in FIG. 1 in accordance with still another embodiment;

[0023] FIG. 16 is a partial section view of a fourth embodiment of the hand guard section shown in FIG. 15;

[0024] FIG. 17 is a partial section view of the hand guard section of the firearm shown in FIG. 1 in accordance with yet another embodiment;

[0025] FIG. 18 is a partial section view of the firearm hand guard section in accordance with yet another embodiment, the handguard being illustrated in one selectable configuration;

[0026] FIG. 19 is a partial section view of the firearm hand guard section showing the handguard section in another configuration;

[0027] FIG. 20 is a partial section view of the firearm hand guard section showing the handguard section in still another configuration; and

[0028] FIG. 21 is a partial section view of the firearm hand guard section showing the handguard section in still another configuration.

DETAILED DESCRIPTION OF THE EXEMPLARY EMBODIMENT(S)

[0029] Referring to FIG. 1, there is shown, a side elevation view of an automatic firearm 10 capable of automatic or semiautomatic fire incorporating features in accordance with an exemplary embodiment of the present invention. Although the present invention will be described with reference to the

embodiments shown in the drawings, it should be understood that the present invention can be embodied in many alternate forms of embodiments. In addition, any suitable size, shape or type of elements or materials could be used.

[0030] Firearm **30** may be gas operated, like examples, such as the M4 or M16 type. Firearm **30** is illustrated as generally having what is known generally as a “black rifle” configuration. The black rifle configuration being the family of rifles developed by Eugene Stoner, for example, such as an M4TM (available from Colt Defense, LLC) or M16 type automatic firearm configuration. Firearm **30** may have operational features such as disclosed in U.S. Pat. Nos. 5,726,377, 5,760,328, 4,658,702 and 4,433,610, all of which are hereby incorporated by reference herein in their entirety. Firearm **30** is illustrated in FIG. 1 as an M4 or M16 type firearm, but the present invention is equally applicable on any other suitable type of firearm. Firearm **30** incorporates a hand guard or accessory mounting system **40** and has line of sight extending from a rear sight to a front sight in a sight plane **100** (see also FIG. 2) for aiming at and acquiring targets. The firearm **30** and its sections described in greater detail below is merely exemplary, and in alternate embodiments the firearm **30** may have other sections, portions or systems. Firearm **30** may incorporate a receiver section **32**, a barrel **34**, gas tube (not shown) and stock **36**. Hand guard **40** may have an upper shell **42** and lower shell **44**. Hand guard **40** may further incorporate vent holes, ribbing, heat shields or double heat shields and liners to facilitate cooling of the barrel **34** while keeping hand guard **40** at a temperature sufficient for an operator. Hand guard **40** may operate as a thermal break between barrel **34** and the user such that the operating temperature of the hand guard is sufficiently lower than that of the barrel to allow use by the operator. Hand guard **40** may have features such as disclosed in U.S. Pat. Nos. 4,663,875 and 4,536,982, both of which are hereby incorporated by reference herein in their entirety. Hand guard **40** may have features for mounting additional or accessory devices **46, A** on an accessory mounting system **51**. The accessory mounting system **51** may have one or more rails **52** (see also FIG. 2) on the hand guard **40**. The outer shell of hand guard **40** may be a composite thermo set molding. In alternate embodiments, other suitable materials or manufacturing techniques may be used; such as cast or fabricated metal or molded or otherwise fabricated plastics or composites for example. Hand guard **40** may be configured to support such rails **52** as a “Piccattiny Rail” configuration as described in Military Standard (Mil-STD) 1913, which is hereby incorporated by reference herein in its entirety. The rails may be made from any suitable material such as hard coat anodized aluminum as an example. In alternate embodiments, other suitable materials may be used, such as other metals or plastics for example. Hand guard **20** may be configured for basic mission profiles or light duty rail requirements while simplifying techniques such as the Gun/Light technique with firearms such as the M4. Peripheral devices **46, A** may be devices such as sights, illumination devices, vision enhancing devices, launchers, laser aiming devices, Global Positioning or aiming devices or otherwise. In alternate embodiments, more or less similar or different devices may be provided and more or less rail(s) may be provided. The rails of the accessory mounting system **51** may be permanently or removably fastened to the hand guard or may be positionable in a number of a selectable positions on the hand guard as will be described further below. The hand guard **40** has a guard casing or sleeve, fastening features **102** coupled to the guard

casing or sleeve and peripheral device mounting rails **52, 54, 104** coupled to the fastening features **102**. The fastening features allow a user to relocate one of the peripheral device mounting rails from a first location **106** on the hand guard casing to a different second location **108** on the hand guard casing or sleeve. The fastening features and mounting rail locations may be put in any of a number of alternate locations. The fastening feature and the hand guard casing cooperate with the peripheral device mounting rails to locate the peripheral device mounting rails in a predetermined orientation relative to the barrel. For example, a peripheral device mounted on one of the peripheral device mounting rails may be located having a peripheral device centerline **110** parallel to (i.e. a columnated barrel firing centerline **112**. Alternately, a peripheral device mounted on one of the peripheral device mounting rails may be located having a peripheral device centerline **114** intersecting a barrel firing centerline **112** at a nominal target position **116**. As an example configuration, when viewed from the firing centerline, the peripheral device mounting rails may be located in a generally “Y” shape pattern such that a first peripheral device mounting rail **104** is located on a lower portion of the guard casing and second and third peripheral device mounting rails **52, 54** are located on opposing sides of an upper portion of the guard casing. As a further example, the second and third mounting rails may be symmetrically located on opposing sides of the upper portion of the guard casing, such as, for example, where the first mounting rail is located nominally at a six o'clock position, and the second and third mounting rails are symmetrically located nominally at a two o'clock and ten o'clock position on opposing sides of the upper portion of the guard casing. In alternate embodiments, other positions could be provided. The peripheral device mounting rails may be placed where peripheral devices mounted on the peripheral device mounting rails do not interfere with the line of sight or the sight plane **100**. As will be described further below, upper and lower portions of the guard casing may comprise molded first and second shells where the first and second shells and may be removable and separable from the firearm **30**. The removable upper and lower portions of the hand guard may be interchangeable respectively with other respective upper and lower hand guard portions having different rail placements thereon. Accordingly an operator may select between different rail configurations by selecting the desired upper and lower hand guard portions (with the desired rail placement) from the different interchangeable hand guard portions with different rail placements. These shells may have venting features for allowing cooling air to pass there through where the fastening features do not substantially prevent the cooling air from traveling through the guard casing and where a heat shield may be mounted within the guard casing. The fastening feature may be a metal insert and may be bonded to an interior surface of the hand guard casing or molded, at least partially, into the hand guard casing. The hand guard casing may have a taper angle with the peripheral device mounting rails having a matching taper angle. Alternately, the hand guard casing may have a taper angle and/or one or more secondary support surfaces located parallel to a barrel firing centerline **112** where the peripheral device mounting rails are located on the support surfaces.

[0031] Referring now to FIG. 2, there is shown a partial top isometric view of the hand guard section of the firearm shown in FIG. 1 and an exemplary accessory A of peripheral device as noted above. Referring also to FIG. 3, there is shown a

partial front isometric view of the hand guard section of the firearm shown in FIG. 1 and the accessory device A. Referring also to FIG. 4, there is shown a partial side elevation view of the hand guard section of the firearm shown in FIG. 1. Referring also to FIG. 5, there is shown a partial side elevation view of the hand guard section of the firearm shown in FIG. 1. Hand guard 40 has an upper sleeve or shell 42 and lower sleeve or shell 44. Hand guard 24 has vent holes 48, external ribbing 50, inner ribbing (see FIG. 6) heat shields or double heat shields and liners such as disclosed in U.S. Pat. No. 4,663,875 which is hereby incorporated by reference in its entirety, to facilitate cooling of the barrel 14 while keeping hand guard 20 at a temperature sufficiently low for an operator. Here, an aluminum rail may be provided in conjunction with a plastic hand guard that acts as an effective thermal break being more effective than if both the hand guard and the rail(s) were constructed out of a single monolithic material, such as aluminum. Rails 52, 54 are provided on hand guard 40 and may be permanently mounted or removably mounted and be removable or moveable to different locations on hand guard 40. For example, aluminum rail sections may be bonded to a plastic hand guard shell. As a further example, an insert may be provided as part of the hand guard shell and an aluminum rail fastened to the shell with fasteners having a male threaded portion with a slightly different pitch lead than a female tapped portion in an extruded portion of the insert. Here, the rails may be removable and the fasteners reusable but with a high resistance to vibration due to the anti-vibration fastening technique. Although rails 52, 54 are shown on the upper shell 42, they may also be mounted on lower shell 44 or in alternate embodiments, multiple rails may be provided in multiple mounting locations on hand guard 40. Fasteners 58 may be provided to attach the rail to an insert 64 (see also FIG. 6) of hand guard 40 that may be provided for mechanical strength and stability. The insert may be a steel insert or an insert made of any other suitable material as described below, or in alternate embodiments may be conventional threaded inserts allowing fastening to plastic or composite structures such as the molded shells of hand guard 40. In alternate embodiments, the insert or fastening feature may be plastic or otherwise directly integrated as part of the hand guard. The insert may be of a stamped or molded sub plate construction with combination of mechanical fasteners, bonding and/or molding for mounting and integration with the hand guard. Mounting of the rails and inserts may be in a manner such that they are vibration and temperature survivable without changing their collimating and alignment features. The rails may have a taper that allows the rail to seat on the surface of the hand guard 40 such that collimating between the rails device mounting features and the barrel centerline are maintained as desired. In this case, orientation of the seating surface of the rail may have compensating taper on the rail to account for any taper of the hand guard, such as the hand guard 40 being tapered for ergonomic reasons. Alternately, the hand guard 40 may have a molded section with a feature such as a flat 76 (see FIG. 16) to maintain a desired orientation of the rail relative to the barrel centerline where the remainder of the hand guard is molded or formed for ergonomic purposes. The flat may be sized to provide seating along the seating surface of the rails. In this manner, hand guard 40 may be fabricated as a very light assembly that does not affect the hand hold of the firearm user. As an alternative to parallel collimating, in alternate embodiments, the device on rails 52, 54 where rails 52, 54 may be angled slightly such that device centerline and barrel

centerline intersect, such as at a targets nominal distance by using the same features and mounting as described, but with this different collimating approach. An inner heat shield (not shown) is provided in hand guard 40 and allows heated air to flow through vent holes 48. Interference of air flowing through hand guard for cooling the barrel and components such as gas line within the hand guard 40 is minimized where the mounting rails and inserts do not interfere with the inner liner. Inserts and fasteners to fasten and support rails 52, 54 are such that they allow an inner liner to be inserted and minimize or not obstruct airflow through hand guard 40. In this manner, the heat shield technology is advanced by adding the mounting features without interfering with heat dissipation.

[0032] Rails 52, 54 may be short mini-rails, longer rails, or multiple rails of same or different length mounted in multiple locations where the insert(s) or rail(s) may be made to accommodate two or more locations on the hand guard 20 and where the insert or rail mounting position(s) can be selectable by the user. The rails mounted to the hand guard may also be selectable from different rails having different configurations that can be mounted to the hand guard 40. For example, the user may select to mount longer or shorter rails to the hand guard, or may select a longer rail for mounting on one side and a shorter rail for mounting on the other side of the hand guard. Rails 52, 54 may be extruded and have extrusion feature(s) that locates them relative to hand guard 40 and may locate on features molded or formed on hand guard 40 or on inserts. Rails 52, 54 may be extruded in shape and have mounting features for peripheral devices, where the mounting features may be disposed so that the peripheral devices are collimated with the bore of barrel 34 and parallel to the bore of barrel 34 upon mounting to the rails. In alternate embodiments, rails 52, 54 may be bonded or fastened to the hand guard 40. In alternate embodiments, hand guard 40 may be modified to change the exterior to provide mounting pads for orienting the rail or the bottom section of the rail (52, 54) may be modified and given angularity to establish different orientation of the mounting surface to maintain collimating. Hand guard 40 may have an integrally molded collimating plane or mounting platform or platforms molded in hand guard 40. Rails 52, 54 are shown mounted at 40 degrees for optimal sight so there is no interference with the sight plane but not so low as to make the peripheral devices difficult to use. As a result, these locations allow optimal rail placement for devices without hindering the sight plane. In alternate embodiments, other angles or multiple angles could be provided. Rails 52, 54 are shown as left and right side rails for ambidextrous use. In alternate embodiments, rails 52, 54 may be mounted further forward or rearward or at different angles. In alternate embodiments, more or less rails could be provided.

[0033] Referring also to FIG. 6, there is shown an isometric view of an interior portion of the hand guard section of the firearm shown in FIG. 1. Upper shell 42 is shown with any heat shields removed exposing insert 60. Fastener holes 62, 64 (in this embodiment, threaded holes) are provided for fastening the rail to the exterior of the shell 42. Insert 60 is shown as a stamped steel construction and bonded to shell 42 with adhesive 66. Elongated slot feature 48 may be provided such that the adhesive 66 or other bonding compound may further encapsulate and capture portions of insert 60 to further secure the adhesive bond or mold to hand guard. Insert 60 may be a sub plate either partially or entirely molded with shell 42 and may further utilize combinations of mechanical

fasteners and bonding. Insert 60 may comprise a steel insert in a recess in hand guard 40. Insert 60 may extend along part or the full length of the hand guard and be bonded or glued in hand guard 40.

[0034] Referring also to FIG. 7, there is shown a side schematic elevation view of the hand guard section 40 of the firearm shown in FIG. 1 in accordance with other exemplary embodiments. Here, alternate mounting features or insert types 70, 72, 74 are shown mounted to the hand guard. In alternate embodiments, the inserts may have more or less mounting features, for example, either along the length of the hand guard or radially around the handguard or both. A collimated molded rail mounting surface 76 is shown in combination with conventional threaded inserts 130, 132. In this embodiment, rails may be mounted on surface 76 using threaded fasteners in combination with inserts 132. Here, hand guard section 40 is tapered as shown; however, the rails may be mounted in a predetermined fashion, such as to be collimated with the firing centerline or as to intersect with the firing centerline. Rails may be mounted in any number of combinations alone or in combination with each other to support single or multiple peripheral devices for left hand or right hand users. Insert 72 provides for multiple mounting positions of the rails. Similarly rail 70 also provides for multiple rail mounting positions. In addition, inserts 74, 76 illustrate different alternate shapes that the mounting inserts may have. In alternate embodiments, different insert shapes or mounting hole patterns may be provided, for example, where the insert has multiple rows of holes or taps.

[0035] Referring also to FIG. 8, there is shown a front schematic elevation view of the hand guard 40 section of the firearm shown in FIG. 1. Here, Alternate rail mounting angles are shown. In alternate embodiments, the same or other angles either alone or in combination could be provided. In alternate embodiments, other angles in combination with alternate radial or lateral positions could be provided.

[0036] Referring also to FIG. 9, there is shown a top elevation view of an insert 60. Referring also to FIG. 10, there is shown a section elevation view of the insert 60 shown in FIG. 9. Insert 60 is shown as a stamped steel assembly having a curved surface 80 intended to generally match the contour of the interior of guard 40. Extruded and tapped mounting features 82, 84 provide the feature to couple the rail to the hand guard. Elongated slot feature 136 is provided to allow potting of adhesive or to provide additional surface area for molding to the hand guard.

[0037] Referring also to FIG. 11, there is shown a partial section view of the hand guard 20 section of the firearm shown in FIG. 1. Features 92 may be cut into rail 94 in order to avoid the ribs on guard 40. In this manner, when the rail is removed or moved to an alternate location, the users gripping surface is not affected. Collimating is maintained by controlling dimension 90 relative to barrel centerline 112 to hold the desired collimating of the rail to the bore centerline. As previously described, and as shown as the alternate embodiments in FIGS. 15 and 16, collimating may be accomplished by tapering rail 94 at interface 140 to match the taper angle 142 on guard 40 or to provide a mounting surface 76 or feature from either the insert 60 or guard 42 to hold the desired collimating. Further, a slot or holes 142 may be provided on rail 94 to locate on the raised taped features of the insert 60 as shown in FIG. 16. In the embodiment of FIG. 16, the molded surface in combination with the slot machined, molded or extruded in the rail locates the rail and fillister screws couple

the rail to the guard 40. In alternate embodiments, other locating and collimating techniques may be used.

[0038] Referring also to FIG. 12, there is shown a partial section view of a first embodiment of the hand guard section of the firearm shown in FIG. 1. In this embodiment, the insert is molded or bonded to the interior surface of guard 4. A combination of flat head screws and the insert locate the rail. Referring also to FIG. 13, there is shown a partial section view of a second embodiment of the hand guard section of the firearm shown in FIG. 1. In this embodiment, the insert is molded or bonded to be recessed in the interior surface of guard 40. A combination of flat head screws and the insert locate the rail. Referring also to FIG. 14, there is shown a partial section view of a third embodiment of the hand guard section of the firearm shown in FIG. 1. In this embodiment, the insert is molded or bonded and encapsulated in the guard 40. A combination of flat head screws and the insert locate the rail.

[0039] Referring also to FIG. 17 through 21 there is shown partial section views of the hand guard section of the firearm shown in FIG. 1 having alternate rail mounting locations. FIG. 17 shows rail 104 mounted at the six o'clock position on casing 44. FIG. 18 shows rail 104 mounted at the six o'clock position on casing 44 with casing 42 coupled to casing 44. FIG. 19 shows rail 104 mounted at the six o'clock position on casing 44 and rails 52, 54 located at the ten o'clock and two o'clock positions on casing 42 with casing 42 coupled to casing 44. FIG. 20 shows rails 52, 54 located at the eight o'clock and four o'clock positions on casing 44 with casing 42 coupled to casing 44. FIG. 21 shows rails 52, 54 located at the ten o'clock and one o'clock positions on casing 42 with casing 42 coupled to casing 44. In alternate embodiments, more or less rails could be provided with more or less alternative mounting locations generally on the hand guard 40. It should be understood that the foregoing description is only illustrative of the invention. Various alternatives and modifications can be devised by those skilled in the art without departing from the invention. Accordingly, the present invention is intended to embrace all such alternatives, modifications and variances which fall within the scope of the appended claims.

1. A firearm having a barrel and an accessory mounting system, the accessory mounting system comprising:
 - a hand guard surrounding a portion of the barrel;
 - peripheral device mounting rails coupled to the hand guard and located about the hand guard in a generally "Y" shape pattern;
 - wherein the generally "Y" shape pattern has a first peripheral device mounting rail located on a lower portion of the hand guard and second and third peripheral device mounting rails located on opposing sides of an upper portion of the hand guard, and wherein the peripheral device mounting rails are placed where peripheral devices mounted on the peripheral device mounting rails do not interfere with a line of sight of the firearm.
2. The firearm of claim 1, wherein the upper and lower portions of the hand guard comprise first and second shells, and wherein the first and second shells are removable from the firearm.
3. The firearm of claim 2, wherein the first and second shells have venting features for allowing cooling air to pass there through, and wherein the fastening features do not substantially prevent the cooling air from traveling through the hand guard.

4. The firearm of claim 1, wherein the fastening features allows a user to selectably move one of the peripheral device mounting rails from a first longitudinal location along the hand guard to a different second longitudinal location along the hand guard.

5. The firearm of claim 1 comprising a black rifle configuration type firearm.

6. The firearm of claim 1, wherein the second and third mounting rails are symmetrically located on opposing sides of the upper portion of the hand guard.

7. The firearm of claim 1, wherein the first mounting rail is located nominally at a six o'clock position, and wherein the second and third mounting rails are symmetrically located nominally at a two o'clock and ten o'clock position on opposing sides of the upper portion of the hand guard.

8. The firearm of claim 1, wherein the hand guard comprises a composite thermo set molding, and wherein the peripheral device mounting rails comprise a metallic material bonded to the hand guard.

9. The firearm of claim 1 wherein the accessory mounting system has a user selectable rail configuration, the accessory mounting system further comprising:

a selectable hand guard section having differently located and arranged peripheral device mounting rails than the upper portion and lower portion of the hand guard and being interchangeable with at least one of the upper or lower portions;

wherein, the selectable hand guard section is selectable for mounting in place of at least one of the upper or lower portions and defining the user selectable rail configuration.

* * * * *